

WARREN RUPP®

Quality System
ISO9001 Certified

Environmental
Management System
ISO14001 Certified

IDEX
IDEX CORPORATION

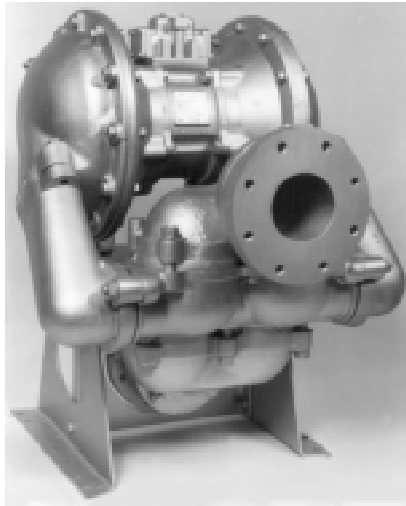

SandPIPER®

BALL VALVE SB4-A Type 3

Air-Powered Double-Diaphragm Pump

ENGINEERING, PERFORMANCE
& CONSTRUCTION DATA

INTAKE/DISCHARGE PIPE SIZE 4" (101mm) ASA Flange	CAPACITY 0 to 260 gallons per minute (0 to 988 liters per minute)	AIR VALVE No-lube, no-stall design.	SOLIDS-HANDLING Up to 7/8" (22.2mm)	HEADS UP TO 125 psi or 289 ft. of water (8.8 Kg/cm ² or 88 meters)
--	--	---	---	--

PERFORMANCE CURVES

(SandPIPER® pumps are designed to be powered **only** by compressed air)
Temperature Limit: 212°F - 100°C MAXIMUM

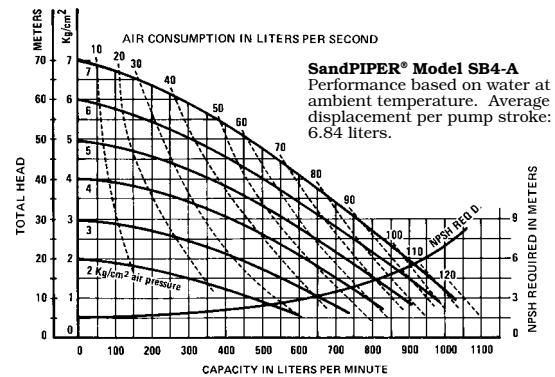
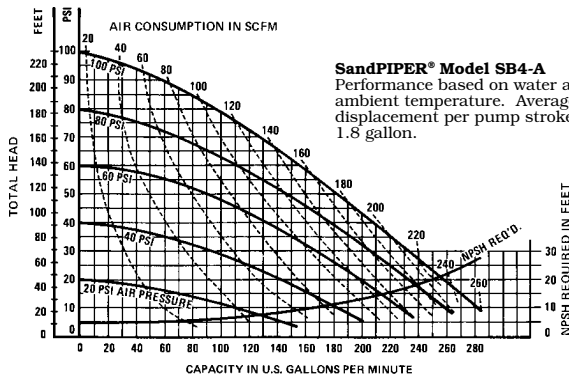

MATERIALS OF CONSTRUCTION

SB4-A Type 3	Manifold Porting			Manifold	Outer Chamber	Inner Chamber	Outer Diaphragm Plate	Inner Diaphragm Plate	Intermediate Housing	Diaphragm Rod	Valve Seat	Hardware	Diaphragm	Ball Valve Material	Seat Gasket	Manifold Gasket Sealing Rings	Shipping Wt.(lbs)
	Top	Side	Bottom														
DB-3-CI			X	CI	CI	CI	PS	PS	CI	416SS	CI	PS	B	B	A	B	490
TB-3-CI	X			CI	CI	CI	PS	PS	CI	416SS	CI	PS	B	B	A	B	490
DI-3-CI		X		CI	CI	CI	PS	PS	CI	416SS	CI	PS	I	I	A	I	490
TI-3-CI	X			CI	CI	CI	PS	PS	CI	416SS	CI	PS	I	I	A	I	490
DN-3-CI			X	CI	CI	CI	PS	PS	CI	416SS	CI	PS	N	N	A	N	490
TN-3-CI	X			CI	CI	CI	PS	PS	CI	416SS	CI	PS	N	N	A	N	490
DC-3-CI			X	CI	CI	CI	PS	PS	CI	416SS	CI	PS	V	T	BG	V	490
TC-3-CI	X			CI	CI	CI	PS	PS	CI	416SS	CI	PS	V	T	BG	V	490

Meanings of Abbreviations:

A = Compressed Fibre
B = Buna-N
BG = Blue Gylon

CI = Cast Iron
I = EPDM
N = Neoprene

PS = Plated Steel
SS = Stainless Steel
T = PTFE

V = Viton®

©Viton is a registered tradename of E.I. DuPont

©Warren Rupp and SandPIPER are registered tradenames of Warren Rupp, Inc.

Available Parts Kits:

Air End Kit:
No: 476-101-000

Wetted End Kit:
Nos: 476-046-365
476-046-364
476-046-360

476-046-633
476-046-635

SB4-A BALL VALVE SandPIPER®

DIAPHRAGM & CHECK VALVE CHARACTERISTICS

Material	Operating Temperatures		
	Maximum*	Minimum*	Optimum**
BUNA-N General purpose, oil-resistant. Shows good solvent, oil, water and hydraulic fluid resistance. Should not be used with highly polar solvents like acetone and MEK, ozone, chlorinated hydrocarbons and nitro hydrocarbons.	190°F 88°C	-10°F -23°C	50°F to 140°F 10°C to 60°C
EPDM Shows very good water and chemical resistance. Has poor resistance to oil and solvents, but is fair in ketones and alcohols.	212°F 100°C	-10°F -23°C	50°F to 212°F 10°C to 100°C
NEOPRENE All purpose. Resistant to vegetable oils. Generally not affected by moderate chemicals, fats, greases and many oils and solvents. Generally attacked by strong oxidizing acids, ketones, esters, nitro hydrocarbons and chlorinated aromatic hydrocarbons.	170°F 77°C	-35°F -37°C	50°F to 130°F 10°C to 54°C
PTFE Chemically inert, virtually impervious. Very few chemicals are known to chemically react with PTFE: molten alkali metals, turbulent liquid or gaseous fluorine and a few fluoro-chemicals such as chlorine trifluoride or oxygen difluoride which readily liberate free fluorine at elevated temperatures.	212°F 100°C	-35°F -37°C	50°F to 212°F 10°C to 100°C
VITON® Shows good resistance to a wide range of oils and solvents: especially all aliphatic, aromatic and halogenated hydrocarbons, acids, animal and vegetable oils. Hot water or hot aqueous solutions (over 70°F) will attack Viton.	212°F 100°C	32°F 0°C	75°F to 212°F 24°C to 100°C

*Definite reduction in service life.
**Minimal reduction in service life at ends of range.

For specific applications, always consult "Chemical Resistance Chart" Technical Bulletin.

Dimensions are ± 1/8"
Figures in parenthesis = millimeters

TOP PORTED

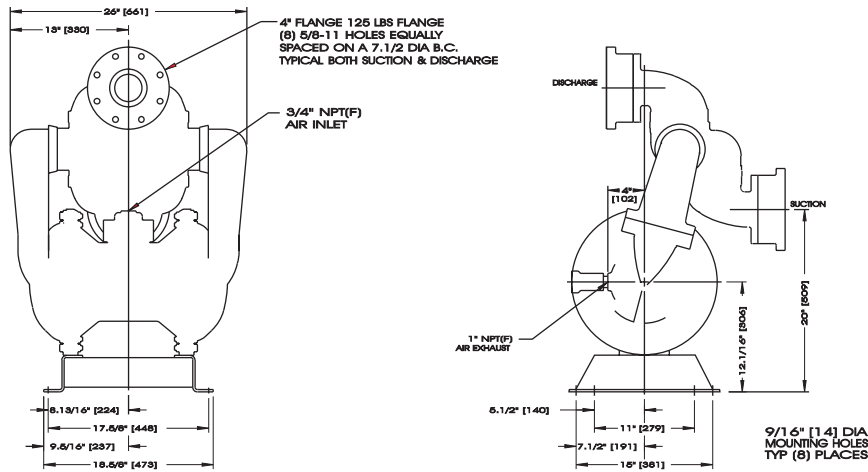

BOTTOM PORTED

