

Discover

SANDPIPER[®] Pumping Solutions

A WARREN RUPP PUMP BRAND

with more ways than one

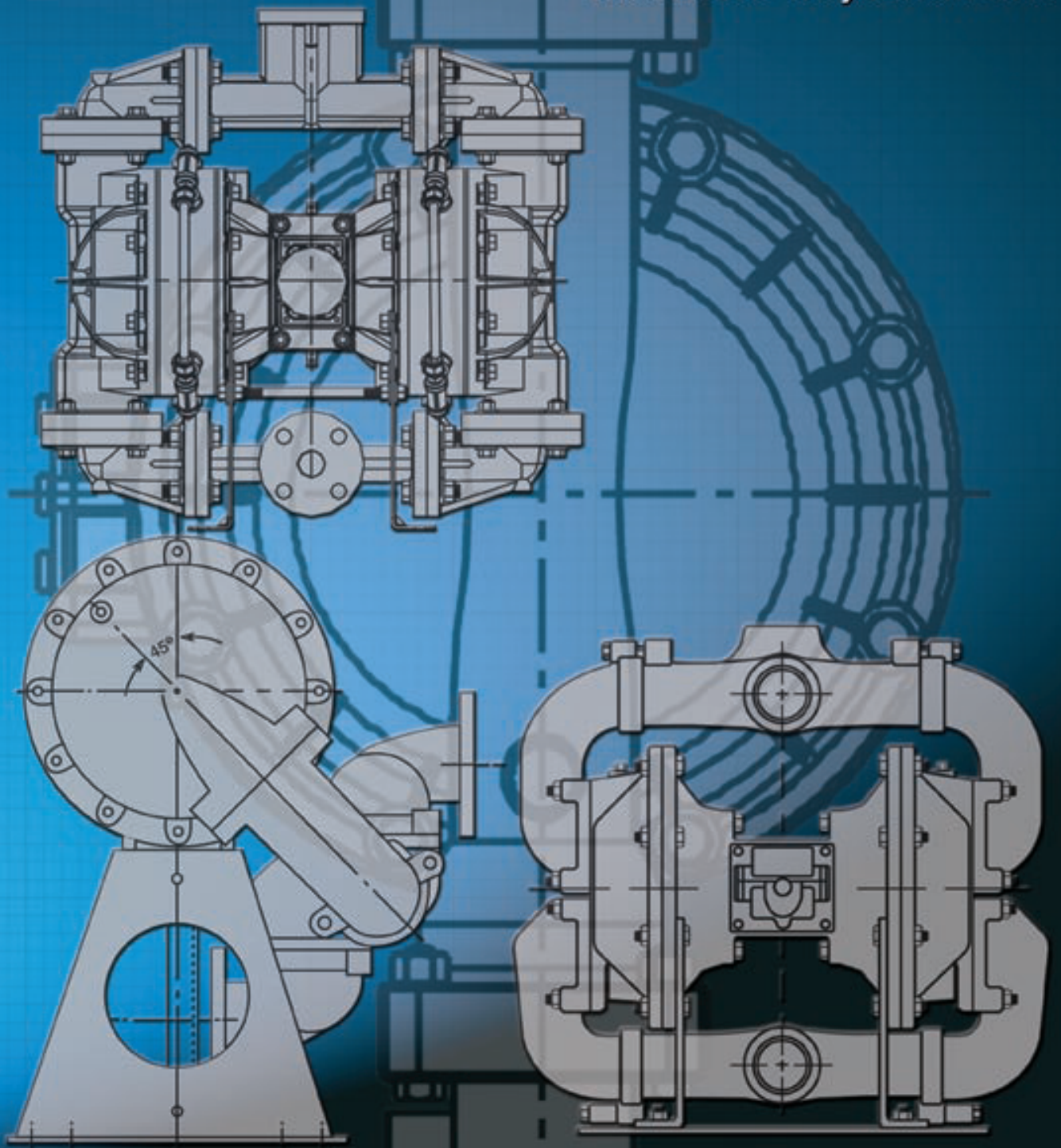

100 PSI

SPECIAL DUTY - USDA (United States Department of Agriculture) Pumps

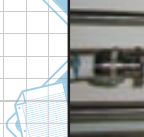
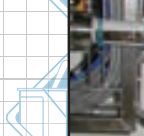

VARIABLE HEADS

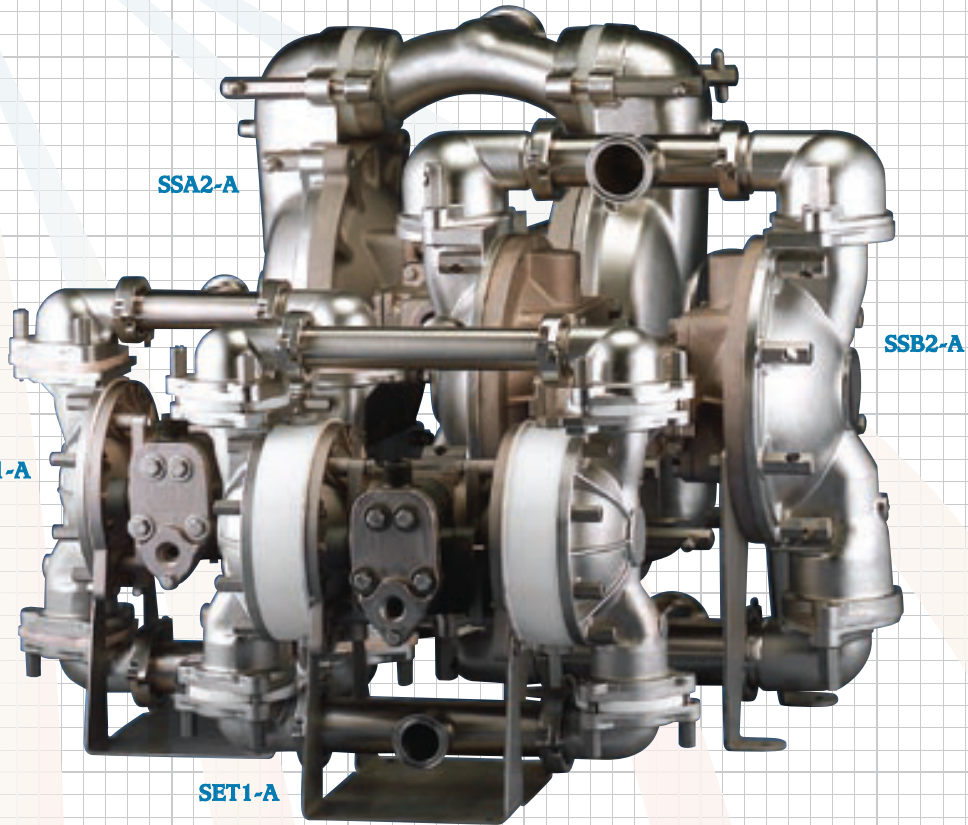

USDA certified flap check valve pumps transferring tomato paste at a major university processing facility.

USDA certified ball check valve pump in a clean-in-place, sanitary piping installation.

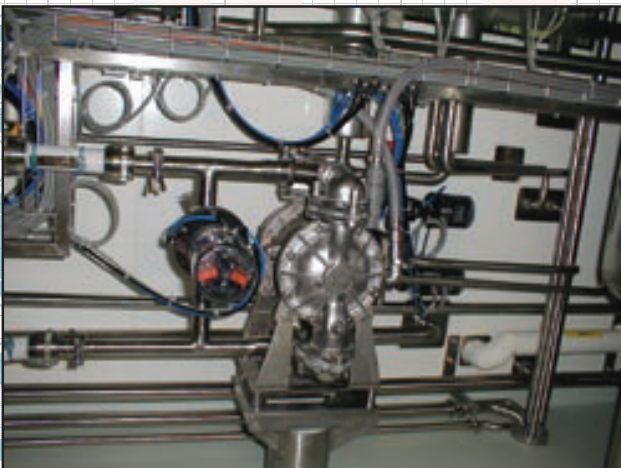

60

VARIABLE FL

100 PSI

SPECIAL DUTY - FDA (Food & Drug Administration) Compliant Pumps

FDA Materials Compliant Pumps are ideally suited for a variety of food processing, pharmaceutical and cosmetic industry applications. The pumps are available in 1" through 3" ball check valve designs and a 2" (line size solids handling) flap check valve design. Variable flow capacities across the range are 0-235 gallons per minute. These special duty pumps are constructed of FDA material compliant components of Stainless Steel (wetted castings) and a selection of FDA Santoprene, FDA Nitrile and PTFE diaphragms, check valves and valve seats. Standard non-wetted components are white epoxy coated Aluminum with stainless steel hardware. 1", 1 1/2" and 2" pumps are offered with sanitary clamp fittings and 3" pumps are offered with an ANSI flange.

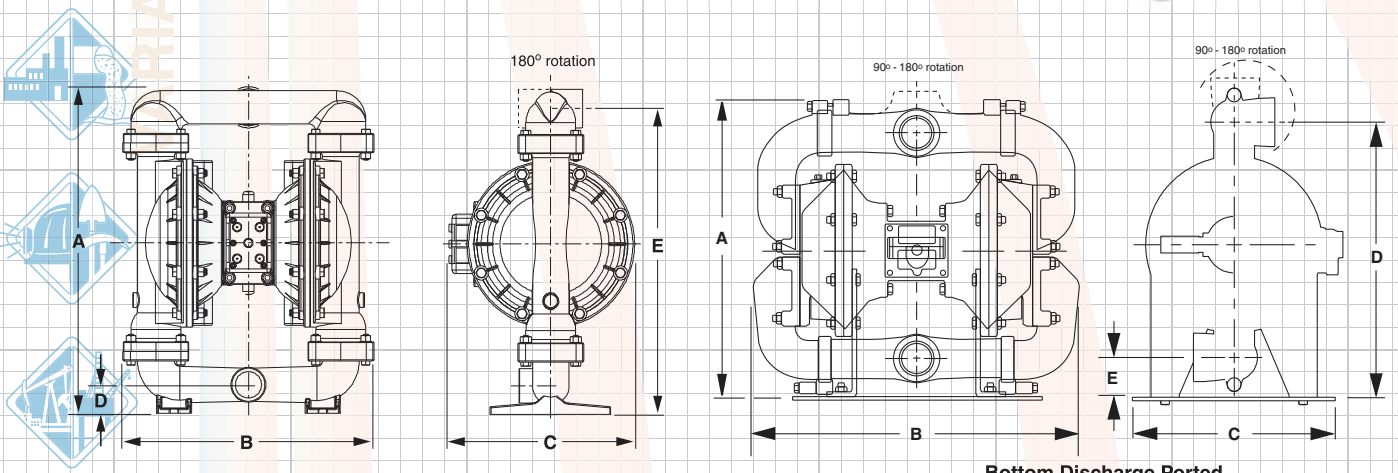
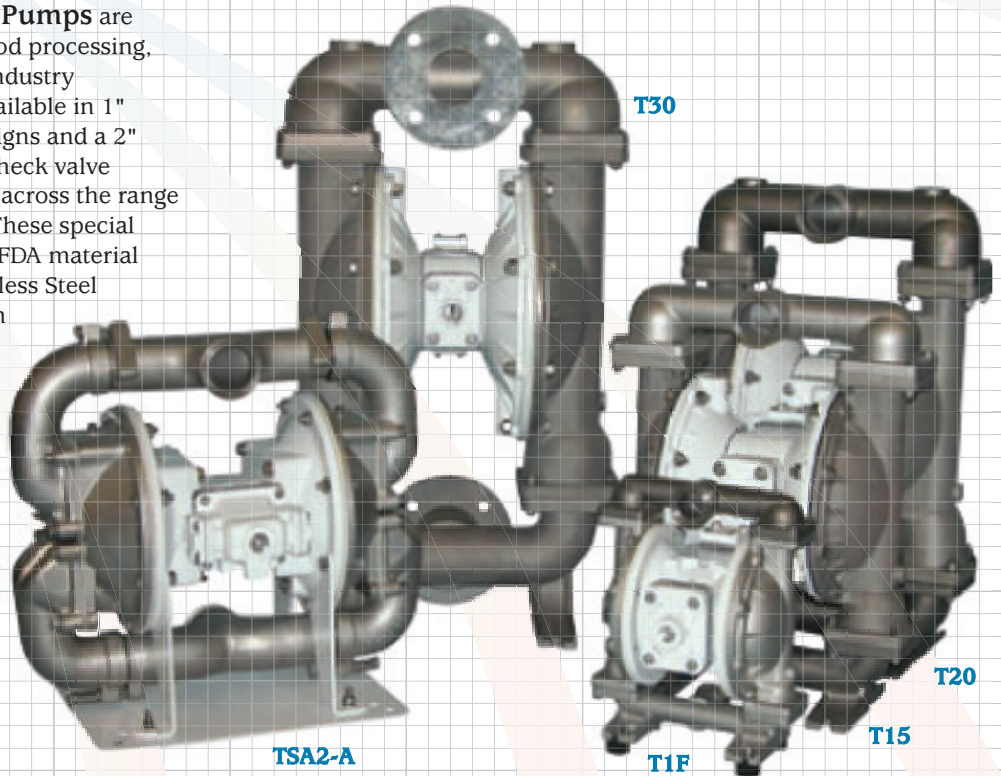

PUMP MODELS	A	B	C	D		E	Connection Style Sanitary Clamp	Pipe Size inch (mm)	Displacement Per Stroke gal (liter)	Max Flow Per Minute gal (liter)	Max Solids Handling inch (mm)	Max Discharge Pressure psi (a)
	Height	Width	Depth	Bottom of Base to Center Line of: Suction Discharge								
	inches (mm)	inches (mm)	inches (mm)	inches (mm)	inches (mm)	(mm)						
TSA2-A	20 13/16 (529)	21 1/4 (539)	18 (330)	2 9/16 (55)	17 9/16 (447)	2 1/2"	Clamp	2 (50)	.43 (1.60)	40 (530)	2 (50)	125 (8.6)
T1F	12 31/32 (326)	10 1/4 (260)	10 3/8 (264)	1 7/32 (31)	11 31/32 (304)	1	1/2" Clamp	1 (25)	.11 (.42)	5 (170)	2.5 (6)	125 (8.6)
T15	21 13/16 (554)	16 21/32 (423)	12 21/64 (314)	1 31/32 (50)	20 3/8 (518)	1.8	2" Clamp	1.5 (40)	41 (1.55)	106 (401)	2.5 (6)	125 (8.6)
T20	26 9/16 (674)	16 7/8 (428)	12 19/32 (320)	2 (51)	24 3/4 (629)	2 1/2"	Clamp	2 (50)	.42 (1.59)	50 (567)	2.5 (6)	125 (8.6)
T30	32 9/32 (820)	19 21/32 (499)	15 3/4 (400)	4 7/32 (107)	30 27/32 (808)		3" # FF ANSI	3 (80)	.94 (3.56)	236 (889)	3.8 (9.5)	125 (8.6)